

A close-up photograph of a white industrial component, possibly a valve or actuator, mounted on a blue frame. The component has several hexagonal bolts on its top surface. A large, stylized, white-outlined watermark of the word "ragazzini" is overlaid across the center of the image.

ragazzini

Rotho[®]

ragazzini



ragazzini

ragazzini

We have been manufacturing pumps for over 60 years, and from the early years we have especially focused on the research and development of the peristaltic pump. Today we are in a position of proposing solutions for every industrial field with the reliability and quality that we have built our success upon.

Simple Principle

The basic principle of the peristaltic pump traces back to human “peristalsis” a term referring to the alternating contraction and relaxation of muscles around a tube to force the contents through it. An elastomeric tube is squeezed along a length by rollers that push the fluid contained within. The tube’s restitution after squeezing produces a vacuum that draws fluid continuously into the tube. This creates a gentle pumping action that doesn’t cause any damage to the product. Contaminations are avoided because the fluid is contained within the tube (one contact part with product). The pump employs a rotor with rollers mounted on it that continually compress and occlude some portion of the tube. This action moves the fluid through the tube with a constant rate of displacement for each revolution of the rotor, enabling a precise measurement of the volume of fluid pumped through the tube.

Rotho®



The Rotho Pump

The “roller on bearings” design of the Rotho pump offers many advantages:

- It eliminates the requirement for adding a lubrication fluid inside the pump housing, because there is no friction on the surface of the tube therefore giving a longer tube life.
- **it requires smaller drives, so less power installed, compared to others peristaltic pumps, to get the same rpm and capacity.**
- They can transfer food products with no contamination hazards, as the pump housing is lubrication free.
- With no lubrication fluid required, hose replacement is greatly simplified and cheaper without having to drain and dispose of a messy and possibly contaminated oil or glycerine solution.



Advantages

No seals

No valves

Self priming

Only tube to replace

Reverse flow by reversing motor

No contact between product and mechanical parts

Can run dry without damage

Able to pump products with solid parts inside

Suitable for CIP applications

Uses

Transfer, feed, meter, filter of:

Fragile or sensitive fluids

Compound fluids

Abrasive and corrosive fluids

Non pollutable or pollutant fluids

Fields of application



Ceramic



Chemical



Water and waste treatments



Food & beverage



Metallurgy



Pulppaper



Construction



Painting and pigment



Ink



Mining



Marine



Biogas

Abrasive Products

The Rotho pump is excellent on abrasive slurries where it has had much more success than other pumps. The Rotho pump parts stay out of the product zone and the hose is the only one thing that is in contact with the product, this keeping abrasive wear to a minimum.

Products that crystallize are also well pumped by the Rotho pump.

There are no valves or glands so the eventual build up of crystals could not clog the pump.



Corrosive Products

With corrosive fluids the hose selection is of paramount importance to the longevity of the pump. With the correct hose selection and no other contact mechanical parts in the product, this ensures a long pump life.



Fluids With Solid Parts or Sensitive Products

A problematic product for many pump types is fluids with solid particles such as waste water with gravel, pieces of wood, concrete or foods, where as the peristaltic pump due to free tube-passage can easily transfer it without any product or pump damage.

The Rotho pump is also a good choice for transferring shear-sensitive fluids or foamy products, the non emulsifying action minimises damage to the product or its consistency.



Viscous Products

The Rotho pump gives a strong self-priming suction which can draw almost full vacuum, producing the pull necessary to draw viscous materials such as honey, grout, resins or waste sludge, which is almost impossible for many other pump types.



Environmental Applications

There are two main environmental applications for the Rotho pump:

- Chemical metering

- Sludge transfer

1) Chemical metering:

The most common is for Sodium Hypochlorite, Sodium Bisulfite, Ferric Chloride and some polymers, as well as lime slurry and carbon slurry. Above all with sodium hypochlorite that emits off gas, the Rotho pump doesn't lose efficiency due to pockets of air, pumping together both liquid and gas

2) Sludge:

The Rotho pump can handle many different kinds of sludge depending upon the level of treatment in a plant. It can feed and transfer thickened sludge, waste activated sludge, return activated sludge and corrosive sludge.



The tube: the heart of the pump

It is an elastomeric tube right for duty service and its selection depends by the product to pump, pressure, temperature; it is a multilayer hose with 2, 4 or 6 textile insert reinforcement depends by its dimension and pressure to win.



TUBE	COMPOSITION	COMPATIBILITY	ΔT (°C)	ΔT (BAR)	WORKING LIFE	FOOD CLASSIFICATION	S.I.P. C.I.P.
● NN	Natural Isoprene (multilayer)	<ul style="list-style-type: none"> ✔ abrasive liquids ✔ moderately aggressive liquids ✔ high pressures 	-10 + 85	-0,9 + 8 (15)	●●●●		
● NP	Food substrate Natural Isoprene (multilayer)	<ul style="list-style-type: none"> ✔ aqueous liquid foods moderately ✔ aggressive liquids 	-10 + 75	-0,9 +6 (8)	●●●●	FDA-CFR 21 Parts 170 to 199 Item 177.2600	*
● EP	Monomer Ethylene Propylene EPDM (multilayer)	<ul style="list-style-type: none"> ✔ chemicals ✔ acids 	-10 + 95	-09 +6 (8)	●●●		
● RN	Nitrile-Butadiene substrate (multilayer)	<ul style="list-style-type: none"> ✔ oils ✔ fats ✔ hydrocarbons ✔ various solvents 	-10 + 75	-09 +6 (8)	●●●		
○ RF	Food substrate Nitril-Butadiene (multilayer)	<ul style="list-style-type: none"> ✔ foods ✔ oils ✔ fats 	-10 + 75	-09 +6 (8)	●●●	FDA 177.2600 DM 21-3.73 IV B	*
● HY	Hypalon substrate Polyethylene Chlorosulphonate (multilayer)	<ul style="list-style-type: none"> ✔ concentrated acids ✔ alkaline liquids ✔ high pressures 	-10 + 85	-0,9 +8	●●●●		
● PH	Thermoplastic Polypropylene (homogeneous) PSF and MSO series only	<ul style="list-style-type: none"> ✔ pharmaceutical products ✔ foods 	-20 +135	-0,5 +1,5 (2)	●●●●	FDA 177.2600 NSF CRITERIA	**

* To sterilize with water 50°C and nitric acid solution 1% or acetic acid 10% or sodium hydroxide 15% for max 10/15 min. Rinse with cold water. Washing with steam to 120°C, max 3 minutes.

** Sanitize with hot water and neutral soap. Rinse with distilled water. Can be sterilised in an autoclave.

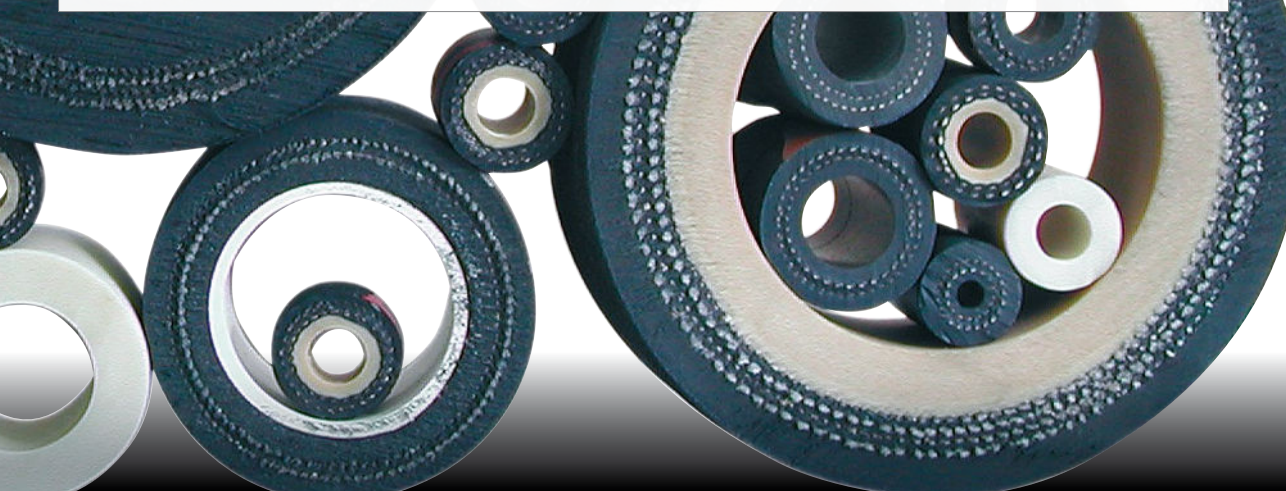

Connections



Flanges DIN; ANSI;
 DIN 11851 Threaded , Clamp, Tri-clamp, RJT, BSP threaded
 In: S.S. 316,
 PVC, PVDF, PTFE
 Polypropylene,
 Titanium

Variable gear speed

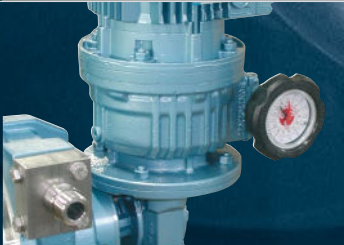

Ratio 1-5

Frequency inverter



Possible arrangement
 for analogical signal 4-20mA, 0-10V.

Pulse dampeners



The pulse dampeners are suggested in case of negative suction and pressure over 2 bar; they ensure a better pump working and a longer tube life.

Three types are available:

Membrane

Empty vessel

Flexible tube

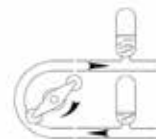

The models of MS and SDF Serie can be equipped of feeder to feed products with solid parts or sensitive parts.

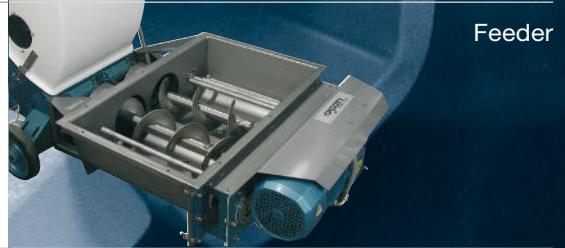

All Rotho pumps (optional for PSF Serie) are equipped of leak detector to provide early indication of hose failure. This is a float type sensor that is located at the lowest point of the pump housing.



The "retractable" position of the roller is instrumental in increasing the lifetime of the tube element. When the pump is not in use for a certain period of time, the tube element can be separated from the roller from outside the pump by activating the rapid release mechanism of the retractable roller, quickly and safely without opening the pump casing.

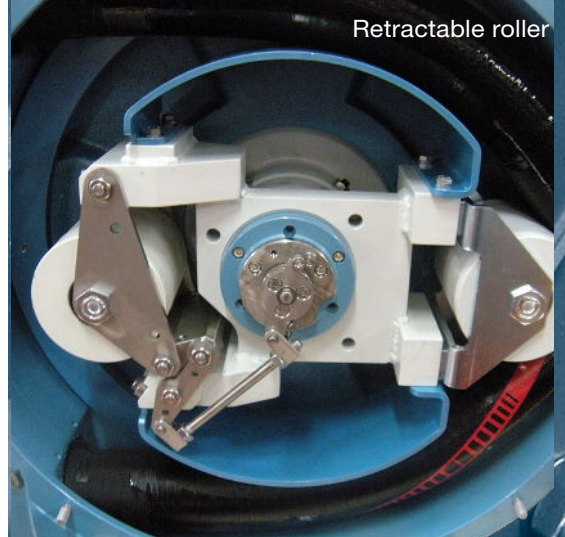

This new positioning system is essential for all those pumps used for fully automated foodstuff handling that requires regular cleaning and sterilization of all components in contact with the product.

In this case, the retractable roller quickly releases the tube element, ensuring perfect CIP and SIP cleaning procedures whenever required.





ragazzini

PSF serie

Capacity/h from 1lt up to 3.100 lt

Pressure up to 8-15 bar

Tubes diameter 5; 10; 16; 26 mm

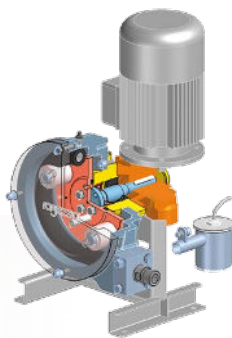

MS serie

Capacity/h from 1.000 lt up to 18.000 lt

Pressure up to 8-15 bar

Tubes diameter 34; 40; 55; 68 mm

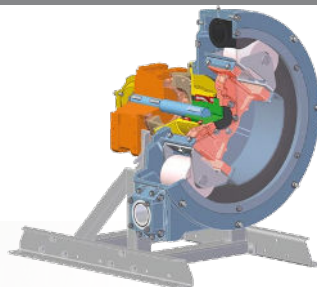

SDF serie

Capacity/h from 10.000 lt up to 70.000 lt

Pressure up to 8-15 bar

Tubes diameter 76; 90 mm

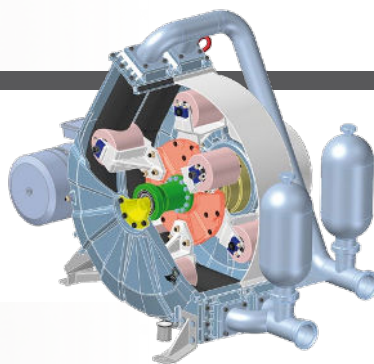

SDR serie

Capacity/h from 80.000 lt up to 180.000 lt

Pressure up to 8-15 bar

Tubes diameter 114; 127 mm

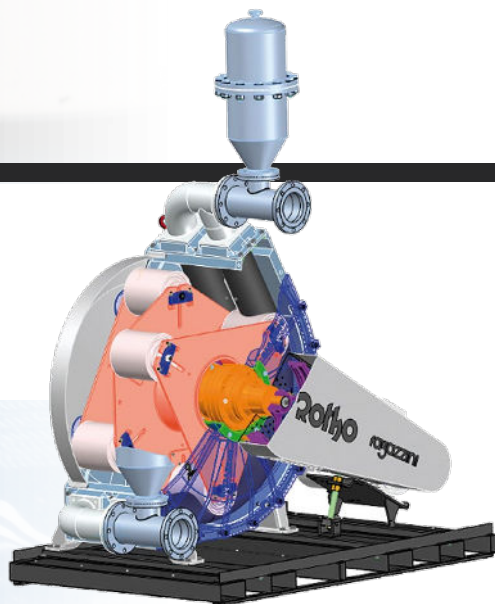

PSF1

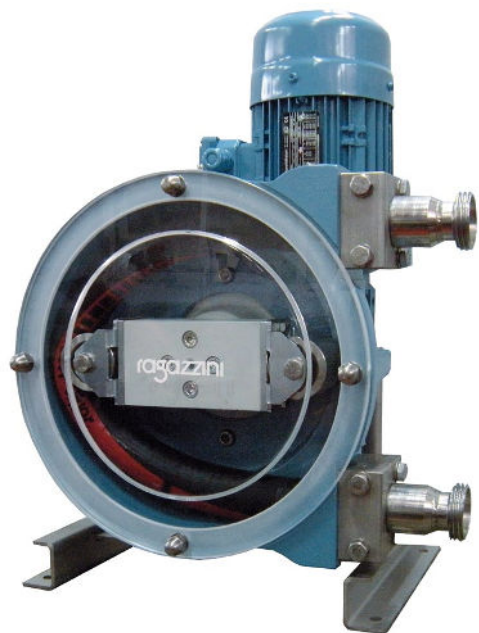

RPM	Lt/h	0-4 bar		Kw
		BAR		
		std	max	
14	308,8	2	4	0,37
18	398,4	2	4	0,37
22	488,1	2	4	0,37
31	689,9	2	4	0,37
37	824,4	2	4	0,37
47	1048,6	2	4	0,75
58	1295,2	2	4	0,75
74	1654,0	2	4	0,75
93	2079,9	2	4	0,75
117	2618,0	2	2	1,1
140	3133,7	2	2	1,1

RPM	Lt/h	4-8 bar		Kw
		BAR		
		std	max	
14	302,4	4	8	0,37
18	390,2	4	8	0,37
22	478,1	4	8	0,37
31	675,8	4	8	0,37
37	807,5	4	8	0,75
47	1027,2	4	8	0,75
58	1268,8	4	8	1,1
74	1620,2	4	8	1,1
93	2037,5	4	6	1,1

variable gear speed 0-4 bar						
RPM		Lt/h		BAR		Kw
max	min	max	min	std	max	
10	1,9	219	37	2	4	0,75
13	2,4	286	49	2	4	0,75
16	3	354	62	2	4	0,75
22	4,2	488	89	2	4	0,75
26	5	578	107	2	4	0,75
33	6,3	735	136	2	4	0,75
42	7,9	937	172	2	4	0,75
53	10	1183	219	2	4	0,75
67	12,7	1497	280	2	4	0,75
83	15,8	1856	349	2	3	0,75
100	19	2237	421	2	3	0,75
143	27,1	3201	602	2	1,5	0,75

variable gear speed 4-8 bar						
RPM		Lt/h		BAR		Kw
max	min	max	min	std	max	
10	1,9	215	37	4	8	0,75
13	2,4	280	48	4	8	0,75
16	3	346	61	4	8	0,75
22	4,2	478	87	4	8	0,75
26	5	566	105	4	8	0,75
33	6,3	720	133	4	8	0,75
42	7,9	917	168	4	6	0,75
53	10	1159	215	4	6	0,75
67	12,7	1466	274	4	4	0,75

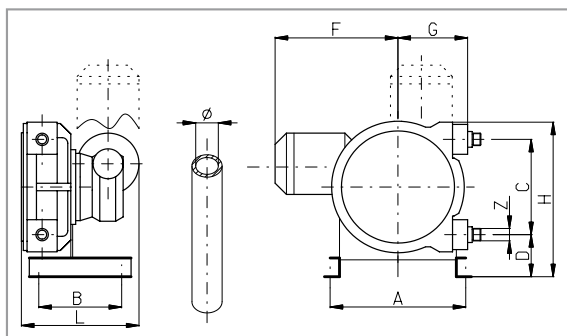

DIMENSIONS

MOD.	Ø mm	Z UNI338	LT/RPM	MAXBAR	A mm	B	C	D	F	G	H	L
PSF1	26	1" 1/4 BSP	0.380	8	350	220	255	108	370	185	416	315

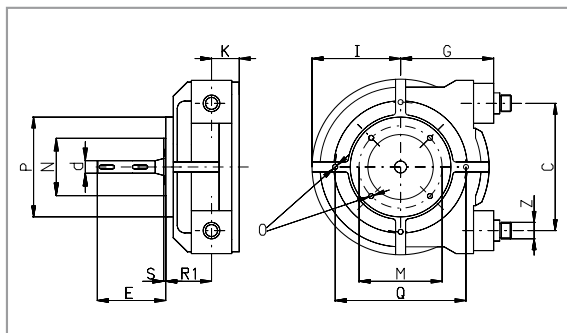

DIMENSIONS

MOD.	Z UNI 338	E	d j6	M	N f7	P	O	I	R1	Q	S	K
PSF1	1" 1/4 BSP	136	25	150	115	200	M10	176	93	260	4	53

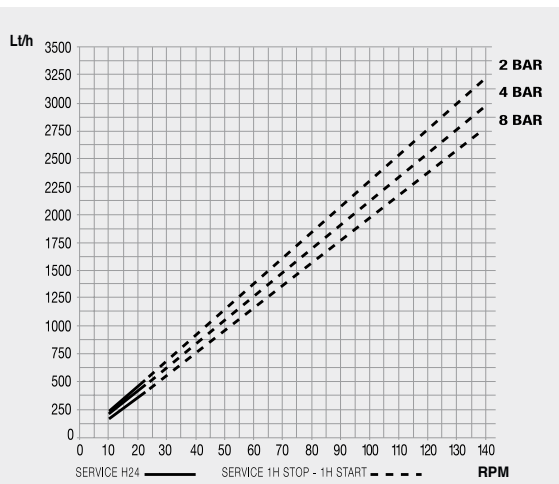

PSF2

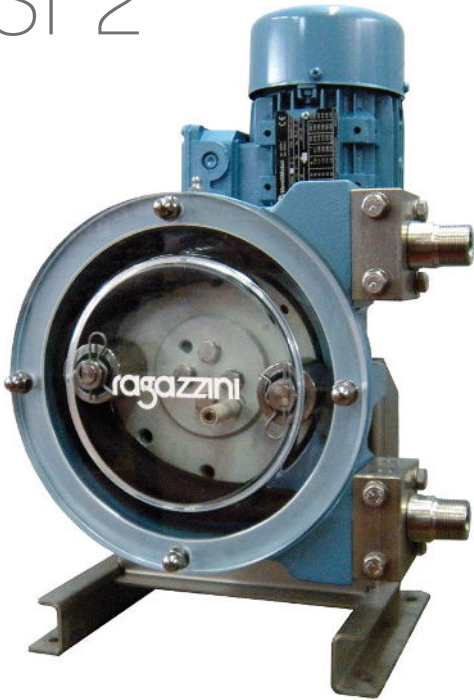

RPM	Lt/h	0-4 bar		Kw
		BAR		
		std	max	
14	75,6	2	4	0,18
20	108,5	2	4	0,18
23	124,9	2	4	0,18
30	163,4	2	4	0,18
40	218,2	2	4	0,37
50	273,1	2	4	0,37
70	382,8	2	4	0,37
100	547,4	2	2	0,37
140	766,9	2	2	0,37

RPM	Lt/h	4-8 bar		Kw
		BAR		
		std	max	
14	74,0	4	8	0,18
20	106,3	4	8	0,18
23	122,4	4	8	0,18
30	160,0	4	8	0,18
40	213,8	4	8	0,37
50	267,5	4	8	0,37
70	375,0	4	8	0,37

variable gear speed 0-4 bar						
RPM		Lt/h		BAR		Kw
max	min	max	min	std	max	
9	1,9	48	9	2	4	0,18
13	2,7	70	14	2	4	0,18
15	3,2	81	16	2	4	0,18
20	4,1	108	21	2	4	0,18
29	5,4	158	28	2	4	0,37
36	6,8	196	36	2	4	0,37
50	9,5	273	51	2	4	0,37
71	13,6	388	73	2	4	0,37
100	19	547	103	2	2	0,37
143	27,1	783	147	2	2	0,37

variable gear speed 4-8 bar						
RPM		Lt/h		BAR		Kw
max	min	max	min	std	max	
9	1,9	47	9	4	8	0,18
13	2,7	69	13	4	8	0,18
15	3,2	79	16	4	8	0,18
20	4,1	106	21	4	8	0,18
29	5,4	155	28	4	8	0,37
36	6,8	192	35	4	8	0,37
50	9,5	268	50	4	8	0,37
71	13,6	380	72	4	6	0,37

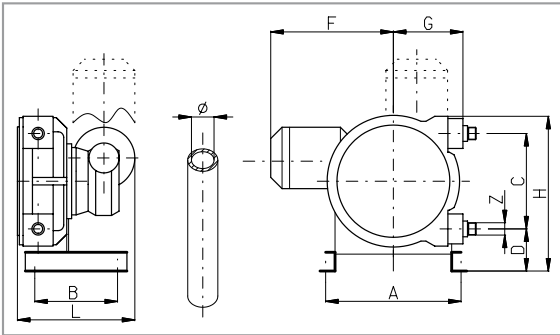

DIMENSIONS												
MOD.	Ø mm	Z UNI338	LT/RPM	MAX BAR	A mm	B	C	D	F	G	H	L
PSF2	16	3/4" BSP	0.093	8	230	160	170	110	290	140	315	242

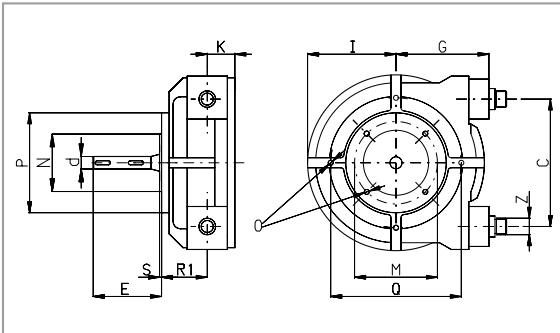

DIMENSIONS												
MOD.	Z UNI 338	E	d j6	M	N f7	P	O	I	R1	Q	S	K
PSF2	3/4" BSP	84	18	87	60	140	M8	120	87	180	3	41

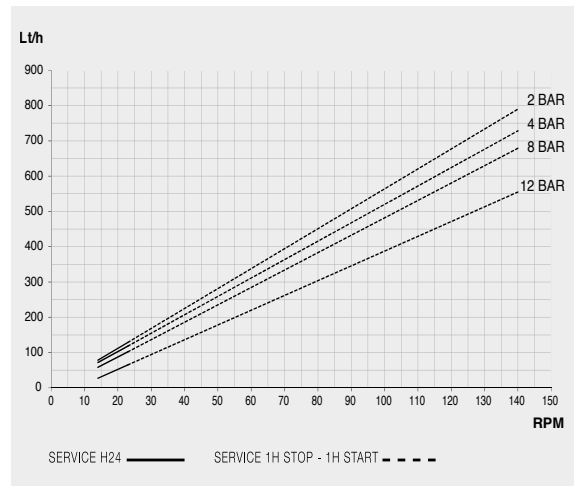

PSF3

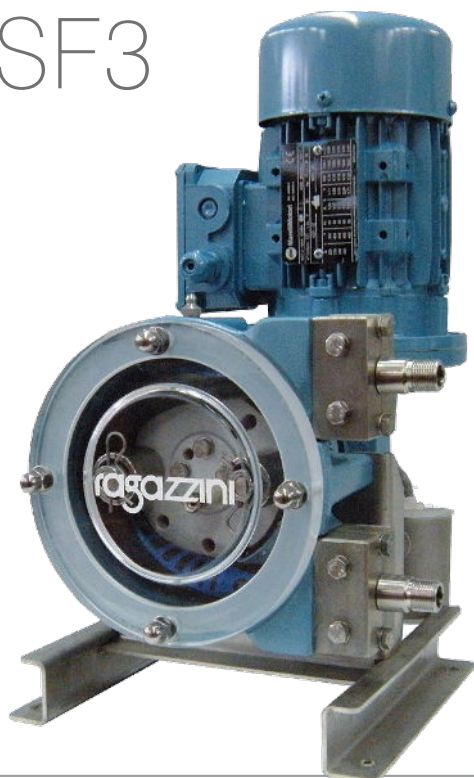

RPM	0-4 bar				Kw
	Lt/h	BAR			
		std	max		
14	19,5	2	4	0,18	
20	28,0	2	4	0,18	
23	32,2	2	4	0,18	
30	42,2	2	4	0,18	
40	56,3	2	4	0,18	
50	70,5	2	4	0,18	
70	98,8	2	4	0,18	
100	141,3	2	4	0,18	
140	197,9	2	2	0,18	

RPM	4-8 bar				Kw
	Lt/h	BAR			
		std	max		
14	19,1	4	8	0,18	
20	27,4	4	8	0,18	
23	31,6	4	8	0,18	
30	41,3	4	8	0,18	
40	55,2	4	8	0,18	
50	69,0	4	8	0,18	
70	96,8	4	8	0,18	
100	138,4	4	8	0,18	

variable gear speed 0-4 bar							Kw
RPM		Lt/h		BAR			
max	min	max	min	std	max		
9	1,9	12	1	2	4	0,18	
13	2,7	18	3	2	4	0,18	
15	3,2	21	3	2	4	0,18	
20	4,1	28	5	2	4	0,18	
26	5,4	36	6	2	4	0,18	
33	6,8	46	8	2	4	0,18	
46	9,5	65	12	2	4	0,18	
65	13,6	92	18	2	4	0,18	
91	19	129	26	2	2	0,18	
130	27,1	184	37	2	2	0,18	

variable gear speed 4-8 bar							Kw
RPM		Lt/h		BAR			
max	min	max	min	std	max		
9	1,9	12	0	4	8	0,18	
13	2,7	18	1	4	8	0,18	
15	3,2	20	2	4	8	0,18	
20	4,1	27	3	4	8	0,18	
26	5,4	36	5	4	8	0,18	
33	6,8	45	7	4	8	0,18	
46	9,5	63	11	4	8	0,18	
65	13,6	90	16	4	8	0,18	

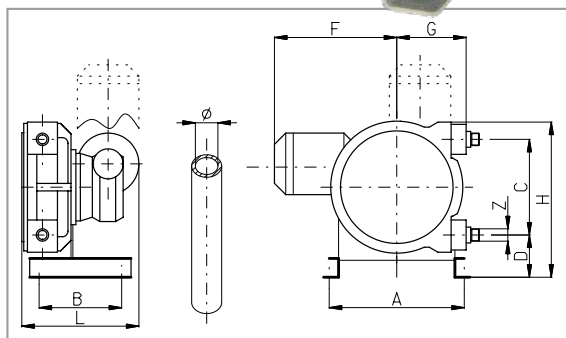

DIMENSIONS

MOD.	Ø mm	Z UNI338	LT/RPM	MAX BAR	A mm	B	C	D	F	G	H	L
PSF3	10	3/8" BSP	0.024	8	210	160	112	94	237	110	238	214

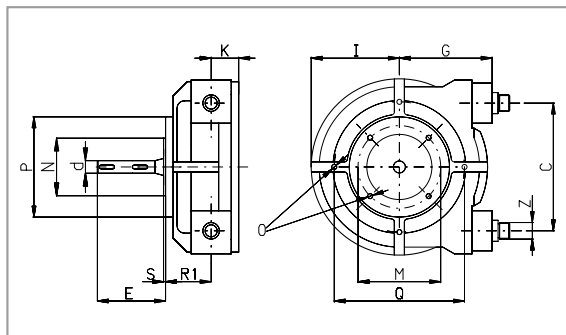

DIMENSIONS

MOD.	Z UNI 338	E	d j6	M	N f7	P	O	I	R1	Q	S	K
PSF3	3/8" BSP	86	18	87	60	108	M8	88	67	160	4	31

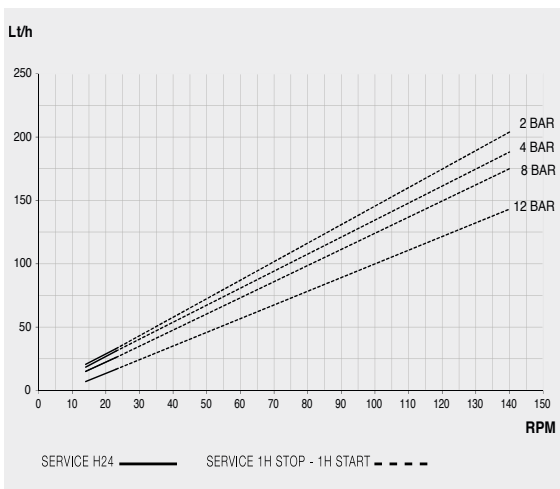

PSF3-S

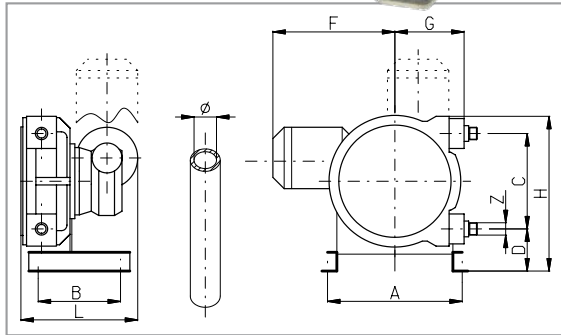
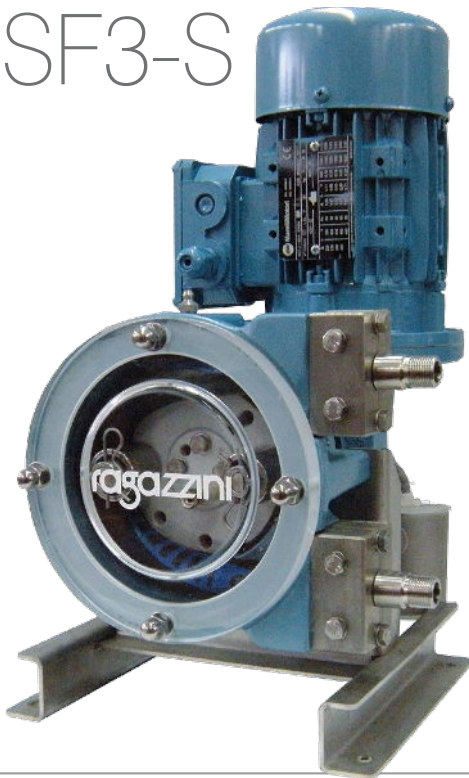

DIMENSIONS												
MOD.	Ø mm	Z UNI338	LT/RPM	MAX BAR	A mm	B	C	D	F	G	H	L
PSF3S	5	3/8" BSP	0.006	12	210	160	112	94	237	110	238	214

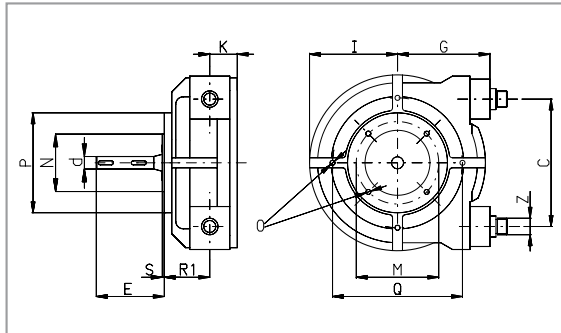

DIMENSIONS												
MOD.	Z UNI 338	E	d j6	M	N f7	P	O	I	R1	Q	S	K
PSF3S	3/8" BSP	86	18	87	60	108	M8	88	67	160	4	31

RPM	Lt/h	0-6 bar		Kw
		BAR		
		std	max	
14	5,3	2	6	0,18
20	7,6	2	6	0,18
23	8,8	2	6	0,18
30	11,5	2	6	0,18
40	15,3	2	6	0,18
50	19,2	2	6	0,18
70	26,9	2	6	0,18
100	38,4	2	6	0,18
140	53,8	2	2	0,18

RPM	Lt/h	6-12 bar		Kw
		BAR		
		std	max	
14	4,9	6	12	0,18
20	7,0	6	12	0,18
23	8,1	6	12	0,18
30	10,7	6	12	0,18
40	14,3	6	12	0,18
50	17,9	6	12	0,18
70	25,2	6	12	0,18
100	36,1	6	12	0,18

variable gear speed 0-6 bar						
RPM		Lt/h		BAR		Kw
max	min	max	min	std	max	
9	1,9	3,4	0,2	2	6	0,18
13	2,7	5,0	0,5	2	6	0,18
15	3,2	5,7	0,7	2	6	0,18
20	4,1	7,6	1,1	2	6	0,18
26	5,4	10,0	1,6	2	6	0,18
33	6,8	12,6	2,1	2	6	0,18
46	9,5	17,6	3,1	2	6	0,18
65	13,6	25,0	4,6	2	6	0,18
91	19	35,0	7,3	2	2	0,18
130	27,1	50,0	10,4	2	2	0,18

variable gear speed 6-12 bar						
RPM		Lt/h		BAR		Kw
max	min	max	min	std	max	
9	5	3,1	0,2	6	12	0,18
13	5	4,5	0,2	6	12	0,18
15	5	5,2	0,2	6	12	0,18
20	5	7,0	0,2	6	12	0,18
26	5,4	9,2	0,3	6	12	0,18
33	6,8	11,8	0,7	6	12	0,18
46	9,5	16,5	1,5	6	12	0,18
65	13,6	23,4	2,7	6	12	0,18

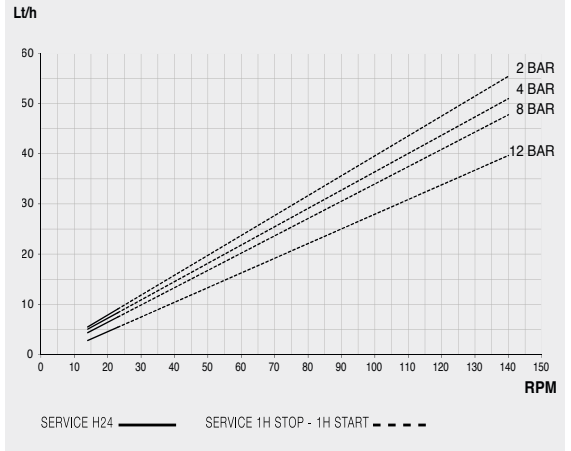

MS0

MS0 MS1 MS2 MS3

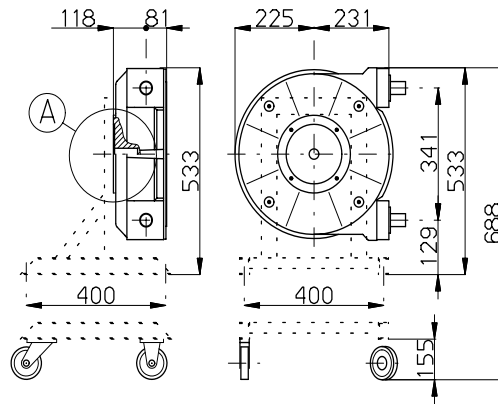
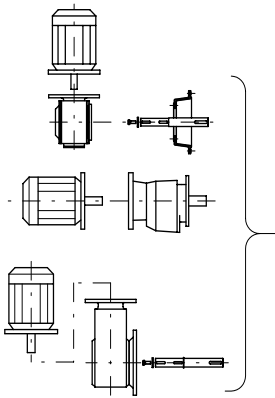

Welding conn. \varnothing 34
 Flange DIN Dn 32
 Flange ANSI 1" 1/4
 Dn 32 DIN 11851
 Threaded BSP 1" 1/4

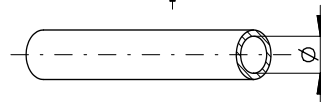
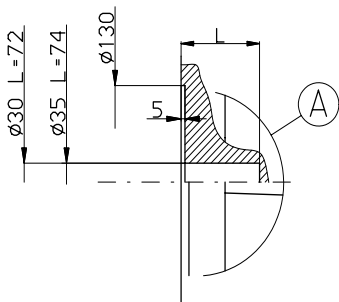

TECHNICAL DATA

MOD.	\varnothing mm	LT/RPM	MAX BAR
MS0	34	0,87	8-15

0-4 bar				
RPM	Lt/h	BAR		Kw
		std	max	
14	687	2	4	0,75
18	893	2	4	0,75
24	1201	2	4	0,75
28	1406	2	4	0,75
36	1817	2	4	1,5
47	2381	2	4	1,5
57	2894	2	4	1,5
71	3613	2	4	1,5
95	4845	2	4	2,2

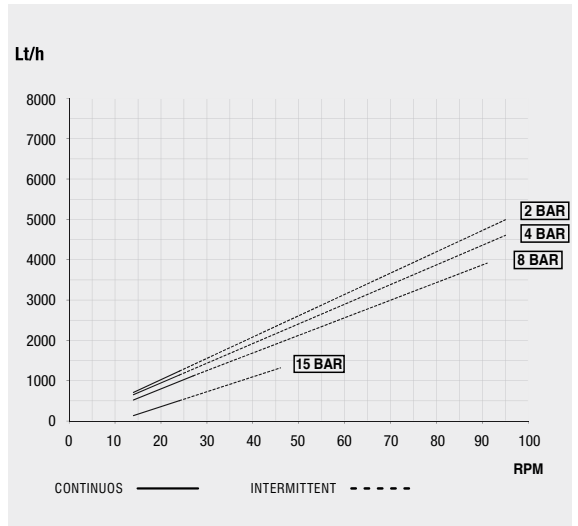

4-8 bar						
RPM		Lt/h		BAR		Kw
max	min	max	min	std	max	
9	1,8	421	59	4	8	0,75
10	2	472	69	4	8	0,75
12	2,3	572	84	4	8	0,75
13	2,5	622	94	4	8	0,75
14	2,8	673	109	4	8	0,75
16	3,2	773	130	4	8	0,75
18	3,6	874	150	4	8	0,75
21	4,2	1025	180	4	8	0,75
25	4,7	1226	205	4	8	1,5
28	5,3	1377	235	4	8	1,5
30	5,7	1477	255	4	8	1,5
34	6,4	1678	291	4	8	1,5
37	7,1	1829	326	4	8	1,5
40	7,6	1980	351	4	8	1,5
44	8,3	2181	386	4	8	1,5
50	9,5	2483	446	4	8	2,2
55	10,4	2734	492	4	8	2,2
64	12,2	3187	582	4	8	2,2
71	13,5	3539	648	4	8	2,2

8-15 bar				
RPM	Lt/h	BAR		Kw
		std	max	
14	520	8	15	0,75
15	566	8	15	0,75
17	659	8	15	1,5
19	751	8	15	1,5
22	889	8	15	1,5
24	981	8	15	1,5
28	1166	8	15	1,5
30	1258	8	15	1,5
35	1489	8	15	2,2
39	1673	8	15	2,2
46	1996	8	15	2,2
50	2180	8	14	2,2
57	2503	8	12	2,2
63	2780	8	8	2,2
72	3195	8	8	2,2

15 bar				
RPM	Lt/h	BAR		Kw
		std	max	
14	134	15	15	0,75
15	171	15	15	0,75
17	245	15	15	1,5
19	319	15	15	1,5
22	430	15	15	1,5
24	504	15	15	1,5
28	652	15	15	1,5
30	726	15	15	1,5
35	910	15	15	2,2
39	1058	15	15	2,2
46	1317	15	15	2,2

variable gear speed 0-4 bar						
RPM		Lt/h		BAR		Kw
max	min	max	min	std	max	
10	1,9	482	66	2	4	0,75
12	2,4	585	92	2	4	0,75
16	3,2	790	133	2	4	0,75
19	3,8	944	164	2	4	0,75
24	4,8	1201	215	2	4	0,75
32	6,3	1611	292	2	4	0,75
40	7,6	2022	359	2	4	1,5
50	9,5	2535	456	2	4	1,5
67	12,7	3408	621	2	4	1,5
100	19	5102	944	2	2	1,5

variable gear speed 4-8 bar						
RPM		Lt/h		BAR		Kw
max	min	max	min	std	max	
9	1,8	453	91	4	8	0,75
10	2	503	101	4	8	0,75
12	2,3	603	116	4	8	0,75
13	2,6	654	131	4	8	0,75
14	2,8	704	141	4	8	0,75
18	3,6	905	181	4	8	0,75
20	4	1006	201	4	8	0,75
21	4,2	1056	211	4	8	0,75
25	4,7	1257	236	4	8	1,5
28	5,3	1408	267	4	8	1,5
31	5,8	1559	292	4	8	1,5
34	6,4	1710	322	4	8	1,5
40	7,6	2011	382	4	8	1,5
44	8,4	2213	422	4	8	1,5
50	9,5	2514	478	4	8	2,2
55	10,5	2766	528	4	6	2,2
64	12,2	3218	613	4	6	2,2
71	13,6	3570	684	4	4	2,2

MS1

MS0 MS1 MS2 MS3

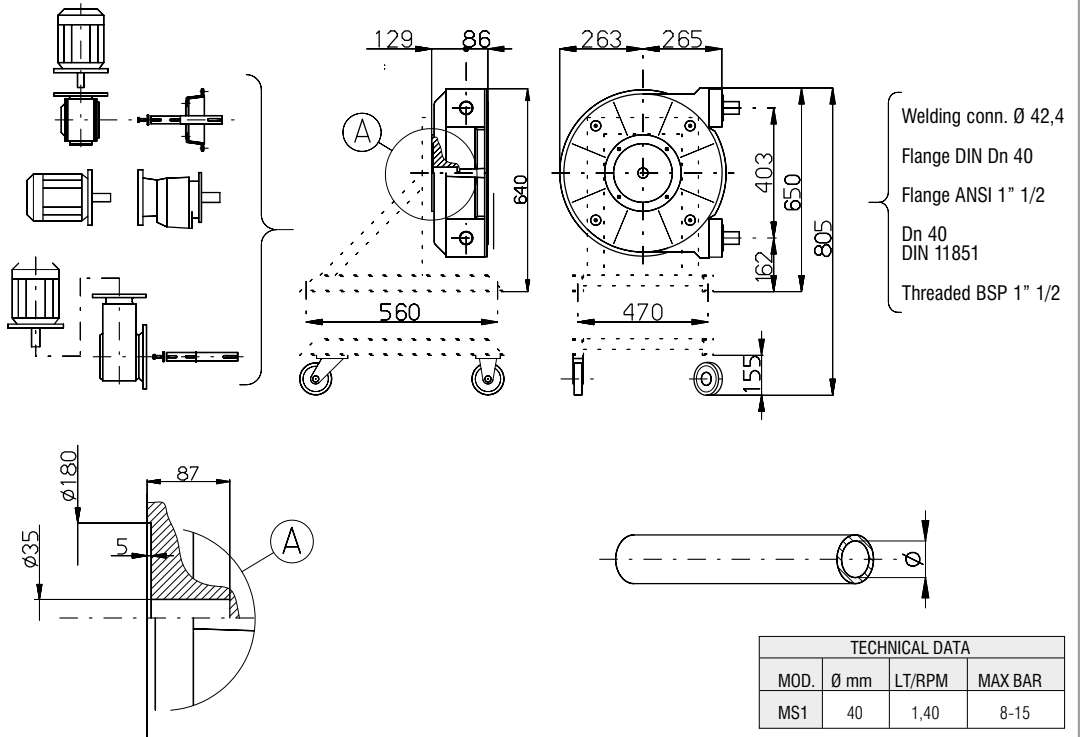
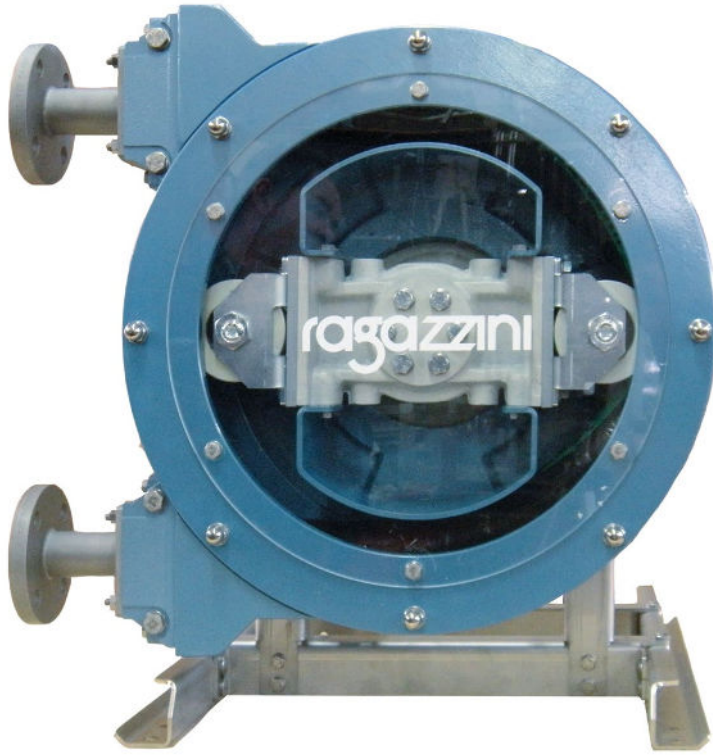

0-4 bar				
RPM	Lt/h	BAR		Kw
		std	max	
14	1114	2	4	0,75
18	1447	2	4	0,75
22	1779	2	4	0,75
25	2029	2	4	1,5
30	2445	2	4	1,5
35	2861	2	4	1,5
47	3859	2	4	1,5
61	5024	2	4	2,2
70	5773	2	4	2,2
93	7686	2	4	3

4-8 bar				
RPM	Lt/h	BAR		Kw
		std	max	
14	1090	4	8	0,75
15	1172	4	8	0,75
17	1335	4	8	0,75
19	1498	4	8	1,5
22	1742	4	8	1,5
24	1905	4	8	1,5
27	2150	4	8	1,5
30	2394	4	8	1,5
35	2802	4	8	1,5
38	3046	4	8	2,2
45	3617	4	8	2,2
49	3943	4	8	2,2
56	4513	4	8	2,2
62	5002	4	4	2,2
71	5906	2	2	2,2
79	6572	2	2	2,2
89	7404	2	2	2,2

8-12 bar				
RPM	Lt/h	BAR		Kw
		std	max	
14	843	8	12	1,5
15	918	8	12	1,5
17	1067	8	12	1,5
19	1217	8	12	2,2
22	1441	8	12	2,2
24	1590	8	12	2,2
27	1815	8	12	2,2
30	2039	8	12	3
35	2413	8	12	3
38	2637	8	12	3
45	3160	8	12	3
49	3459	8	8	3
56	3982	8	8	3
62	4430	8	8	3
71	4849	8	6	3
79	5447	8	4	3
89	6194	8	4	3

15 bar				
RPM	Lt/h	BAR		Kw
		std	max	
14	217	15	15	1,5
15	277	15	15	1,5
17	397	15	15	1,5
19	517	15	15	2,2
22	697	15	15	2,2
24	816	15	15	2,2
27	996	15	15	2,2
30	1176	15	15	3
35	1476	15	15	3
38	1655	15	15	3
45	2075	15	15	4

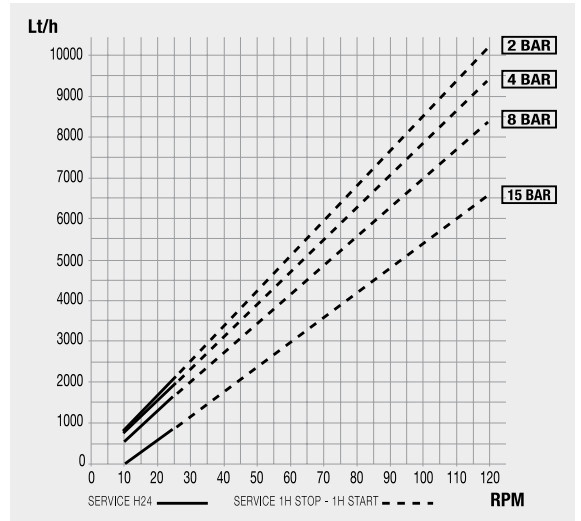

variable gear speed 0-4 bar						
RPM		Lt/h		BAR		Kw
max	min	max	min	std	max	
10	1,9	781	107	2	4	0,75
12	2,4	948	149	2	4	0,75
15	3	1197	199	2	4	0,75
17	3,4	1363	232	2	4	0,75
22	4,1	1779	290	2	4	1,5
25	4,8	2029	349	2	4	1,5
33	6,3	2695	473	2	4	1,5
43	8,3	3526	640	2	4	1,5
50	9,5	4109	740	2	4	1,85
67	12,7	5523	1006	2	2	1,85
100	19	8268	1530	2	2	2,2

variable gear speed 4-8 bar						
RPM		Lt/h		BAR		Kw
max	min	max	min	std	max	
9	1,9	683	104	4	8	0,75
10	2	764	112	4	8	0,75
12	2,3	927	137	4	8	0,75
13	2,6	1009	161	4	8	1,5
16	3	1253	194	4	8	1,5
17	3,2	1335	210	4	8	1,5
19	3,7	1498	251	4	8	1,5
21	4	1661	275	4	8	1,5
25	4,7	1987	332	4	8	1,85
27	5,2	2150	373	4	8	1,85
32	6,1	2557	446	4	8	2,2
35	6,7	2802	495	4	8	2,2
40	7,6	3209	569	4	8	2,2
44	8,4	3535	634	4	8	3
51	9,6	4106	732	4	8	3
56	10,7	4513	821	4	6	3
63	12	5084	927	4	6	3
89	17	7203	1335	4	4	3

MS2

MS0 MS1 MS2 MS3

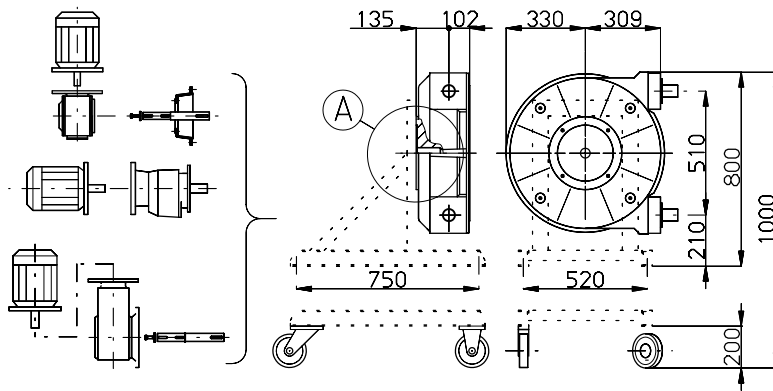
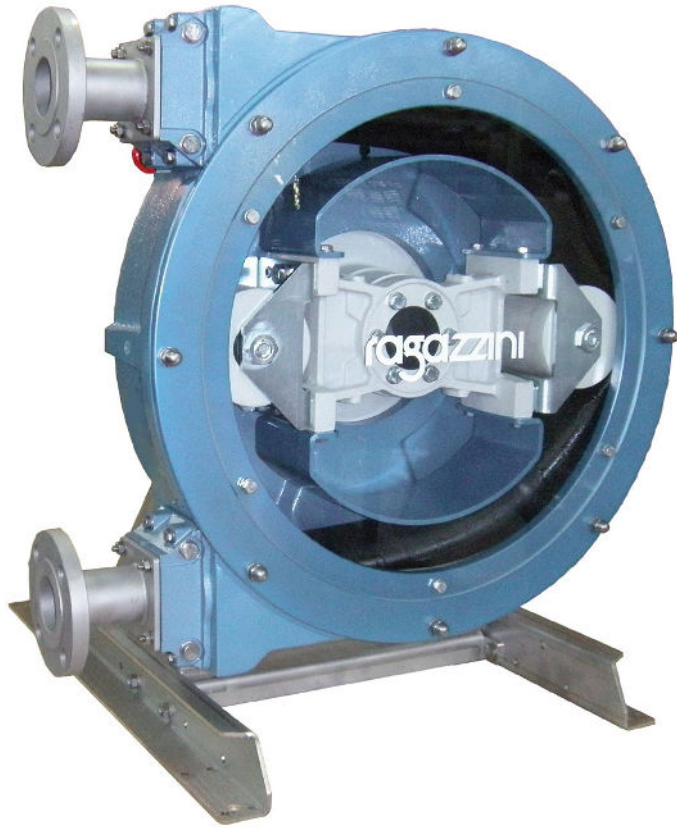

- Welding conn. Ø 60,3
- Flange DIN Dn 50
- Flange ANSI 2"
- Dn 50
DIN 11851
- Threaded BSP 2"

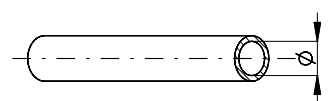
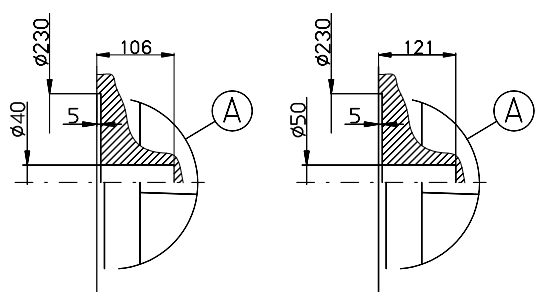

TECHNICAL DATA			
MOD.	Ø mm	LT/RPM	MAX BAR
MS2	55	3,20	8-15

0-4 bar				
RPM	Lt/h	BAR		Kw
		std	max	
14	2528	2	4	1,5
15	2717	2	4	1,5
18	3283	2	4	1,5
19	3472	2	4	1,5
22	4038	2	4	1,5
24	4416	2	4	1,5
27	4982	2	4	2,2
30	5549	2	4	2,2
35	6493	2	4	2,2
38	7059	2	4	2,2
47	8758	2	4	3
54	10080	2	4	3
60	11213	2	4	4
67	12534	2	4	4
74	13856	2	3	4
84	15744	2	2	4
93	17443	2	2	4

4-8 bar				
RPM	Lt/h	BAR		Kw
		std	max	
14	2474	4	8	2,2
15	2659	4	8	2,2
18	3214	4	8	2,2
19	3399	4	8	2,2
22	3954	4	8	2,2
24	4324	4	8	3
27	4879	4	8	3
30	5434	4	8	3
35	6358	4	8	4
38	6913	4	8	4
47	8578	4	6	4
54	9873	4	5	4
60	10982	4	4	4
67	12277	4	4	4
74	13226	4	3	4
84	15076	4	2	4
93	16740	4	2	4

8 bar				
RPM	Lt/h	BAR		Kw
		std	max	
14	1914	8	8	2,2
15	2083	8	8	2,2
18	2592	8	8	2,2
19	2762	8	8	2,2
22	3270	8	8	2,2
24	3610	8	8	3
27	4118	8	8	3
30	4627	8	8	3
35	5475	8	8	4
38	5984	8	8	4
47	7510	8	6	4
54	8698	8	5	4
60	9715	8	4	4
67	10902	8	4	4
74	12090	8	3	4
84	13786	8	2	4
93	15312	8	2	4

15 bar				
RPM	Lt/h	BAR		Kw
		std	max	
14	493	15	15	3
15	629	15	15	3
17	901	15	15	3
19	1173	15	15	4
21	1445	15	15	4
24	1853	15	15	4
26	2125	15	15	5
29	2533	15	15	5

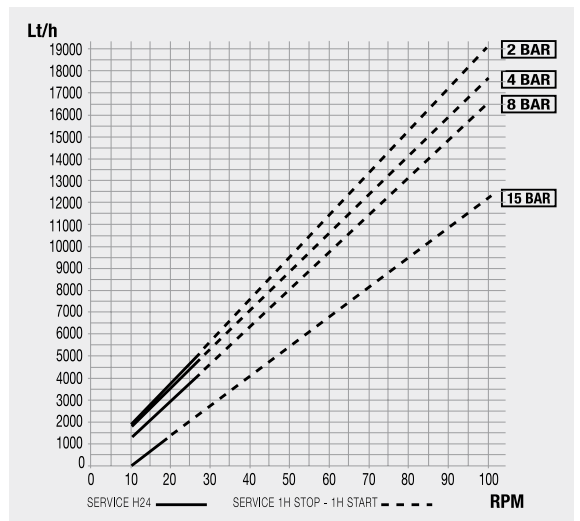

variable gear speed 0-4 bar						
RPM		Lt/h		BAR		Kw
max	min	max	min	std	max	
10	1,9	1773	244	2	4	0,75
11	2	1962	262	2	4	0,75
13	2,4	2339	338	2	4	1,5
14	2,6	2528	376	2	4	1,5
15	2,9	2717	432	2	4	1,5
17	3,2	3094	489	2	4	1,5
20	3,7	3661	583	2	4	1,5
21	4,1	3850	659	2	4	1,5
25	4,7	4605	772	2	4	2,2
27	5,1	4982	848	2	4	2,2
33	6,3	6115	1074	2	4	2,2
39	7,3	7248	1263	2	4	3
43	8,1	8003	1414	2	4	3
48	9	8947	1584	2	4	3
53	10,1	9891	1792	2	4	4
60	11,4	11213	2037	2	4	4
67	12,7	12534	2283	2	3,5	4
85	16,1	15933	2924	2	2	4

variable gear speed 4-8 bar						
RPM		Lt/h		BAR		Kw
max	min	max	min	std	max	
10	1,9	1734	236	4	8	2,2
11	2	1919	255	4	8	2,2
13	2,4	2289	329	4	8	2,2
14	2,6	2474	366	4	8	2,2
15	2,9	2659	421	4	8	2,2
17	3,2	3029	477	4	8	3
20	3,7	3584	569	4	8	3
21	4,1	3769	643	4	8	3
25	4,7	4509	754	4	8	4
27	5,1	4879	828	4	8	4
33	6,3	5988	1050	4	8	4
39	7,3	7098	1235	4	6	5,5
43	8,1	7838	1383	4	6	5,5
48	9	8763	1549	4	6	5,5
53	10,1	9688	1753	4	6	5,5
60	11,4	10982	1993	4	6	7,5
67	12,7	12277	2234	4	6	7,5
85	16,1	15606	2863	4	4	7,5

variable gear speed 6-12 bar						
RPM		Lt/h		BAR		Kw
max	min	max	min	std	max	
10	1,8	1670	206	6	12	2,2
11	2,1	1849	260	6	12	2,2
12	2,3	2028	295	6	12	3
13	2,6	2206	349	6	12	3
15	2,8	2563	385	6	12	3
17	3,2	2920	456	6	12	4
19	3,6	3277	528	6	12	4
21	4	3635	599	6	12	4
28	5,3	4884	831	6	12	5,5

MS3

MS0 MS1 MS2 MS3

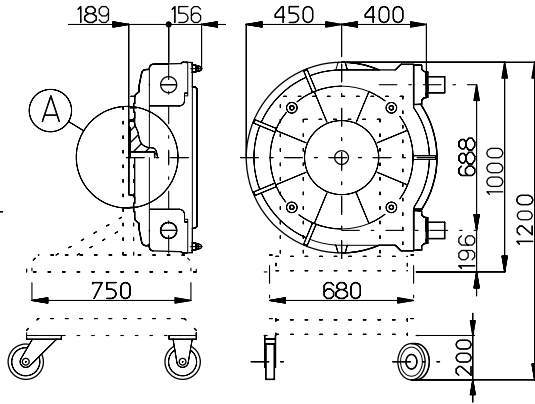
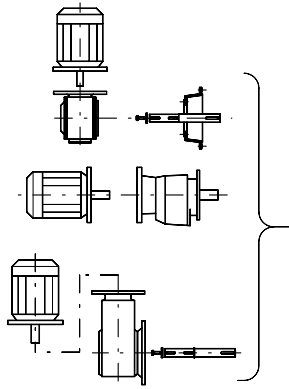

- Welding conn. Ø 76,1
- Flange DIN Dn 65
- Flange ANSI 2" 1/2
- Dn 65
DIN 11851
- Threaded BSP 2" 1/2

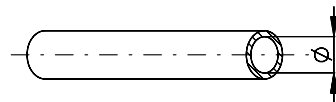
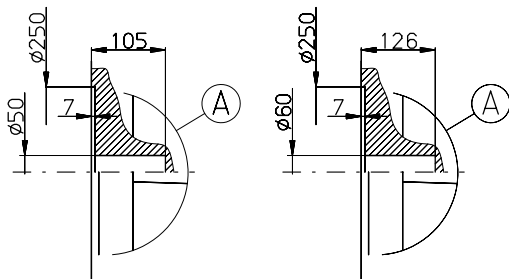

TECHNICAL DATA			
MOD.	Ø mm	LT/RPM	MAX BAR
MS3	68	6,80	8-15

0-4 bar				
RPM	Lt/h	BAR		Kw
		std	max	
14	5372	2	4	2,2
15	5773	2	4	2,2
17	6576	2	4	2,2
19	7378	2	4	2,2
21	8180	2	4	3
24	9384	2	4	3
26	10186	2	4	3
29	11390	2	4	4
32	12594	2	4	4
39	15402	2	4	5,5
42	16606	2	4	5,5
51	20216	2	4	7,5
56	22222	2	4	7,5
63	25031	2	3	7,5
71	28240	2	3	7,5
79	31450	2	2	7,5

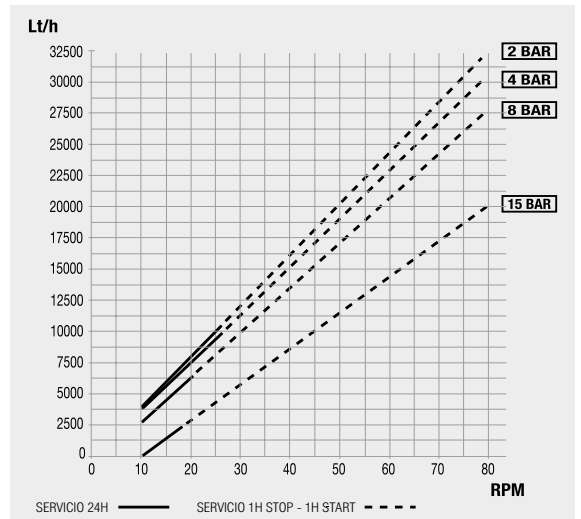

4-8 bar				
RPM	Lt/h	BAR		Kw
		std	max	
14	5258	4	8	3
15	5651	4	8	3
17	6437	4	8	4
19	7223	4	8	4
21	8009	4	8	4
24	9188	4	8	5,5
26	9974	4	8	5,5
29	11153	4	8	7,5
32	12332	4	8	7,5
39	15084	4	6	7,5
42	16263	4	6	7,5
51	19800	4	5	7,5
56	21765	4	4	7,5
63	24517	4	3	7,5
71	27661	4	3	7,5
79	30805	4	2	7,5

variable gear speed 0-4 bar						
RPM		Lt/h		BAR		Kw
max	min	max	min	std	max	
10	1,8	3767	477	2	4	2,2
11	2,1	4168	598	2	4	2,2
12	2,3	4570	678	2	4	2,2
13	2,6	4971	798	2	4	2,2
15	2,8	5773	879	2	4	2,2
17	3,2	6576	1039	2	4	4
19	3,6	7378	1200	2	4	4
21	4	8180	1360	2	4	4
23	4,4	8983	1520	2	4	4
28	5,3	10989	1882	2	4	4
30	5,8	11791	2082	2	4	7,5
36	6,9	14198	2523	2	4	7,5
40	7,7	15803	2844	2	4	7,5
45	8,5	17809	3165	2	4	7,5
51	9,7	20216	3647	2	4	7,5
56	10,7	22222	4048	2	4	7,5
63	11,9	25031	4529	2	3	7,5

8-10 bar				
RPM	Lt/h	BAR		Kw
		std	max	
13	3706	8	10	4
16	4787	8	10	4
17	5148	8	10	5,5
20	6229	8	10	5,5
21	6589	8	10	5,5
25	8031	8	10	7,5
27	8752	8	10	7,5
31	10193	8	10	11
34	11274	8	10	11

variable gear speed 4-8 bar						
RPM		Lt/h		BAR		Kw
max	min	max	min	std	max	
10	1,8	3686	463	4	8	4
11	2,2	4079	620	4	8	4
12	2,3	4472	659	4	8	4
14	2,7	5258	816	4	8	4
15	2,9	5651	895	4	8	4
18	3,4	6830	1092	4	8	7,5
19	3,6	7223	1170	4	8	7,5
22	4,3	8402	1445	4	8	7,5
24	4,6	9188	1563	4	8	7,5
29	5,5	11153	1917	4	8	9,2
36	6,9	13905	2467	4	6	9,2
44	8,3	17049	3017	4	6	9,2

15 bar				
RPM	Lt/h	BAR		Kw
		std	max	
13	758	15	15	7,5
16	1625	15	15	7,5
18	2203	15	15	7,5
19	2492	15	15	7,5
22	3359	15	15	11
26	4515	15	15	11
31	5960	15	12	11

variable gear speed 6-10 bar						
RPM		Lt/h		BAR		Kw
max	min	max	min	std	max	
10	1,8	3550	438	6	10	4
11	2,2	3929	590	6	10	4
12	2,3	4308	628	6	10	4
14	2,7	5067	780	6	10	5,5
15	2,9	5447	856	6	10	5,5
18	3,4	6585	1045	6	10	7,5
19	3,6	6965	1121	6	10	7,5
22	4,3	8103	1387	6	10	7,5
24	4,6	8862	1501	6	10	7,5
29	5,5	10759	1842	6	8	9,2
36	6,9	13415	2373	6	8	9,2
44	8,3	16451	2905	6	6	9,2

SF100



Welding conn. Ø 88,9

Flange DIN Dn 80

Flange ANSI 3"

Dn 80
DIN 11851

Threaded BSP 3"

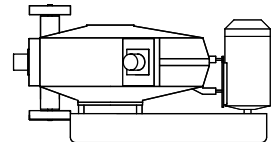
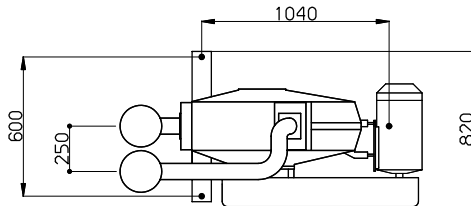
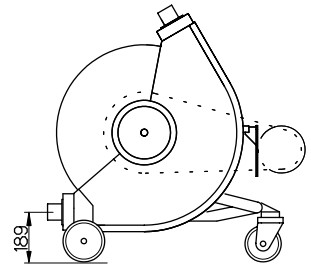
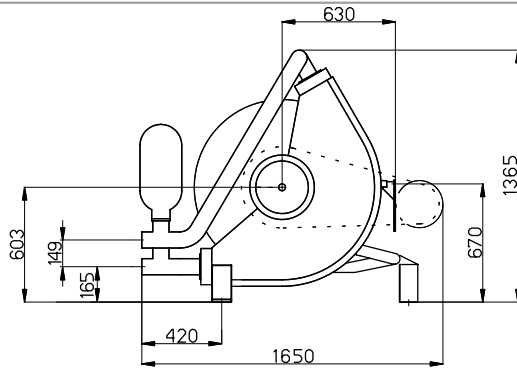

TECHNICAL DATA			
MOD.	Ø mm	LT/RPM	MAX BAR
SF	75	10,5	8-15

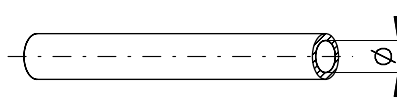

0-4 bar					
RPM	Lt/h	BAR		Kw	
		std	max		
14,7	8981	2	4	5,5	
19,3	11830	2	4	5,5	
23,2	14246	2	4	5,5	
27,7	17034	2	4	5,5	
29,2	17963	2	4	5,5	
36,6	22548	2	4	7,5	
43,6	26884	2	4	7,5	
46	28371	2	3	7,5	
48,8	30106	2	3	7,5	

4-6 bar					
RPM	Lt/h	BAR		Kw	
		std	max		
14,7	8795	4	6	5,5	
19,3	11587	4	6	5,5	
23,2	13954	4	6	7,5	
27,7	16685	4	6	7,5	
31	18688	4	6	11	
39	23543	4	6	11	
43,6	26335	4	5	11	

8 bar					
RPM	Lt/h	BAR		Kw	
		std	max		
16,6	8734	8	8	7,5	
18,5	9791	8	8	7,5	
21	11183	8	8	11	
23,5	12574	8	8	11	
26,3	14132	8	8	11	
29,6	15968	8	8	15	
33	17861	8	8	15	
37	20087	8	8	15	
41,1	22368,15	8	6	15	

15 bar					
RPM	Lt/h	BAR		Kw	
		std	max		
16,6	5864	15	15	11	
18,5	6712	15	15	11	
21	7828	15	15	15	
23,5	8943	15	15	15	
26,3	10193	15	12	15	
29,6	11666	15	12	15	
33	13183	15	10	15	

variable gear speed 0-4 bar						
RPM		Lt/h		BAR		Kw
max	min	max	min	std	max	
20,1	3,8	12326	2228	2	4	5,5
25,2	4,8	15485	2848	2	4	5,5
30	5,7	18459	3405	2	4	7,5
38,2	7,3	23539	4396	2	4	9,2
48,1	9,1	29672	5511	2	2,5	9,2

variable gear speed 4-6 bar						
RPM		Lt/h		BAR		Kw
max	min	max	min	std	max	
20,1	3,8	12073	2180	4	6	5,5
25,2	4,8	15168	2787	4	6	7,5
30	5,7	18081	3333	4	6	9,2
38,2	7,3	23058	4304	4	5	9,2
48,1	9,1	29066	5397	4	3	9,2

variable gear speed 4-8 bar						
RPM		Lt/h		BAR		Kw
max	min	max	min	std	max	
20,7	3,6	12437	2059	4	8	11
26,3	4,5	15835	2605	4	8	11
29,6	5,1	17838	2969	4	8	11
37	6,4	22329	3758	4	6	11
47,3	8,2	28580	4851	4	4	11

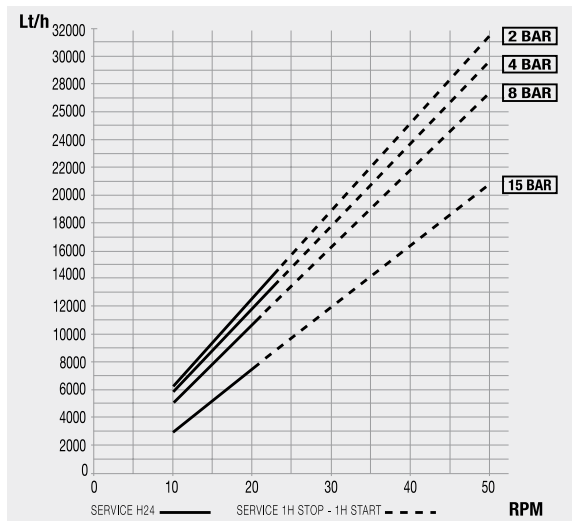

SF190

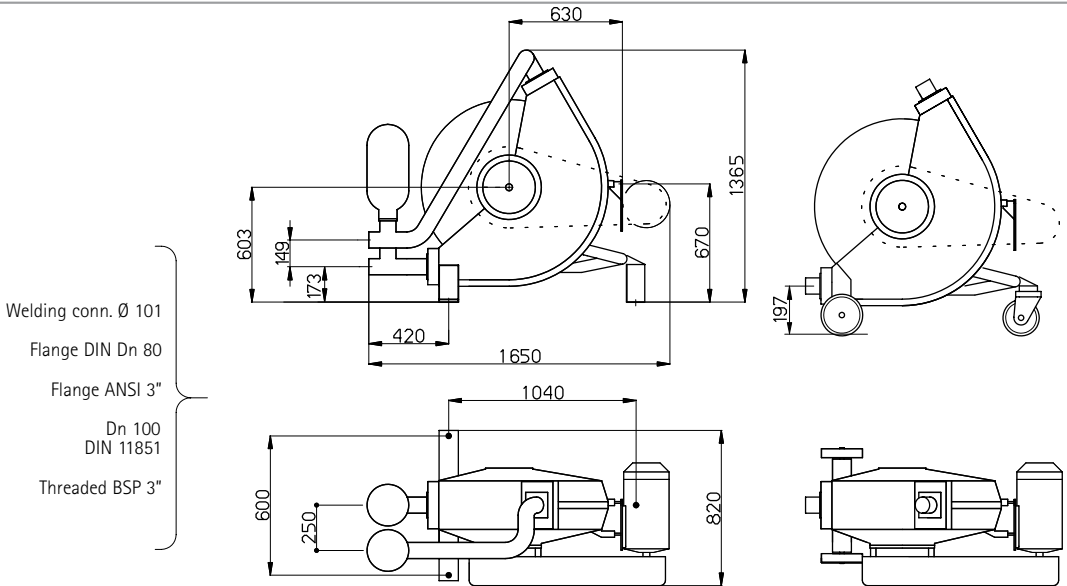

TECHNICAL DATA			
MOD.	Ø mm	LT/RPM	MAX BAR
SF	90	14,5	8-15

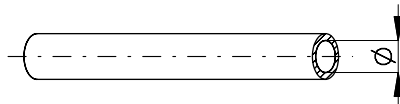

0-4 bar				
RPM	Lt/h	BAR		Kw
		std	max	
14,9	11706	2	4	5,5
19,6	15449	2	4	5,5
23,6	18635	2	4	5,5
28,1	22220	2	4	7,5
29,7	23494	2	4	7,5
35,5	28114	2	4	11
39,7	31459	2	4	11
41,8	33132	2	3,5	11

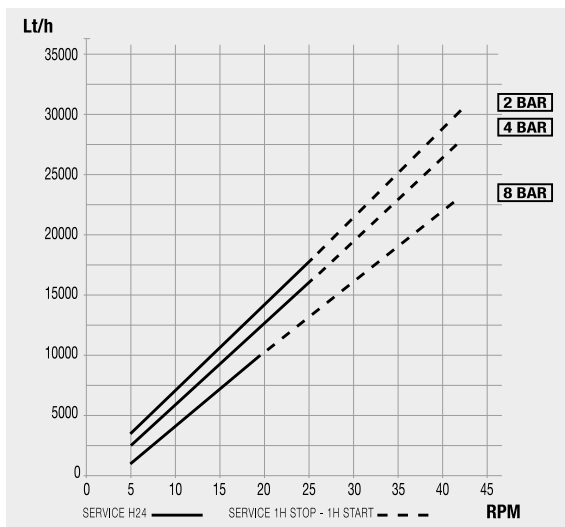

4-8 bar				
RPM	Lt/h	BAR		Kw
		std	max	
16,9	13025	4	8	11
18,8	14508	4	8	11
21,4	16536	4	8	11
23,9	18487	4	8	11
26,8	20750	4	8	15
30,1	23325	4	8	15
33,6	26056	4	8	15
37,6	29177	4	7	15
41,8	32455	4	6	15

8 bar				
RPM	Lt/h	BAR		Kw
		std	max	
16,9	11444	8	8	11
18,8	12803	8	8	11
21,4	14664	8	8	11
23,9	16452	8	8	11
26,8	18527	8	8	15
30,1	20889	8	8	15
33,6	23393	8	8	15
37,6	26255	8	7	15
41,8	29260	8	6	15

Variable gear speed 0-3,5 bar						
RPM		Lt/h		BAR		Kw
max	min	max	min	std	max	
20,1	3,8	15848	2865	2	3,5	5,5
25,2	4,8	19910	3661	2	3,5	7,5
30	5,7	23733	4378	2	3,5	7,5
36,1	6,9	28592	5334	2	3	9,2
42,9	8,2	34008	6369	2	2,5	9,2

Variable gear speed 4-8 bar						
RPM		Lt/h		BAR		Kw
max	min	max	min	std	max	
19,4	3,3	14976	2413	4	8	11
24,3	4,1	18799	3037	4	6	11
34,7	5,9	26914	4442	4	5	11
38,7	6,6	30036	4988	4	4	11

DF100



Welding conn. Ø 88,9

Flange DIN Dn 80

Flange ANSI 3"

Dn 80
DIN 11851

Threaded BSP 3"

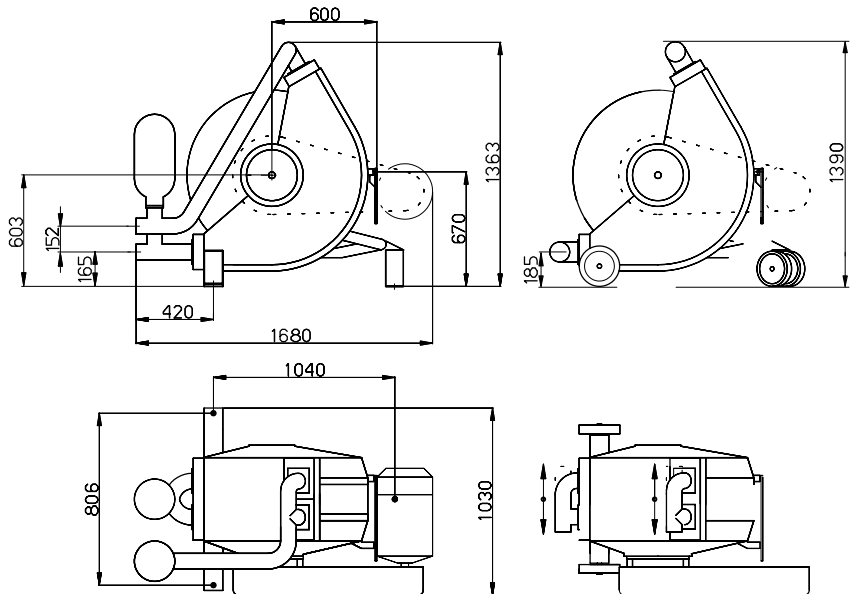

TECHNICAL DATA			
MOD.	Ø mm	LT/RPM	MAX BAR
DF	75	21	8

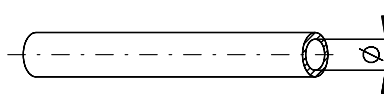

0-3,5 bar				
RPM	Lt/h	BAR		Kw
		std	max	
14,7	17961	2	3,5	7,5
18,3	22422	2	3,5	7,5
22,1	27130	2	3,5	7,5
27,7	34068	2	3,5	11
29,2	35927	2	3,5	11
34,9	42989	2	3,5	11
43,6	53768	2	3,5	15
46	56742	2	3,5	15

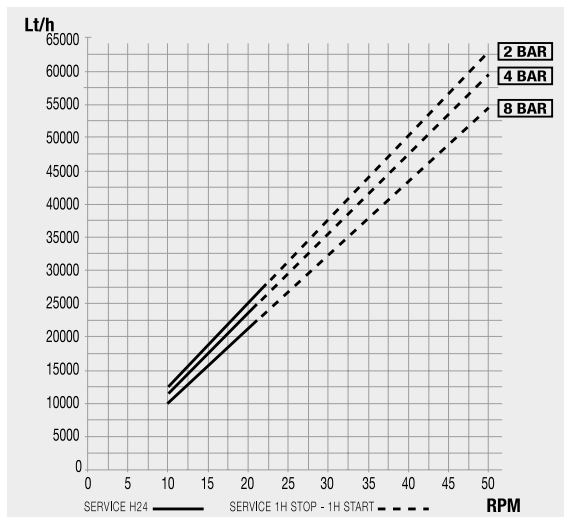

4-8 bar				
RPM	Lt/h	BAR		Kw
		std	max	
16,6	19897	4	8	11
18,5	22203	4	8	11
21	25238	4	8	15
23,5	28272	4	8	15
26,3	31671	4	8	15
29,6	35676	4	6	15
33	39803	4	6	15
37	44659	4	6	18,5
41,1	49635	4	5	18,5
46	55583	4	5	18,5

8 bar				
RPM	Lt/h	BAR		Kw
		std	max	
16,6	17468	8	8	11
18,5	19583	8	8	11
21	22365	8	8	15
23,5	25148	8	8	15
26,3	28264	8	8	15
29,6	31937	8	6	15
33	35721	8	6	15
37	40173	8	6	18,5

variable gear speed 0-2,5 bar						
RPM		Lt/h		BAR		Kw
max	min	max	min	std	max	
20,1	3,8	24652	4456	2	3,5	7,5
25,2	4,8	30971	5695	2	3,5	9,2
30	5,7	36918	6810	2	2,5	9,2
38,2	7,3	47078	8793	2	2,5	9,2
48,1	9,1	59344	11023	2	1,6	9,2

variable gear speed 4-6 bar						
RPM		Lt/h		BAR		Kw
max	min	max	min	std	max	
20,7	3,6	24874	4118	4	6	15
26,3	4,5	31671	5210	4	6	15
29,6	5,1	35676	5938	4	6	15
37	6,4	44659	7516	4	6	18,5
47,3	8,2	57161	9701	4	4	18,5

DF190



Welding conn. Ø 101
 Flange DIN Dn 100
 Flange ANSI 4"
 Dn 100
 DIN 11851
 Threaded BSP 4"

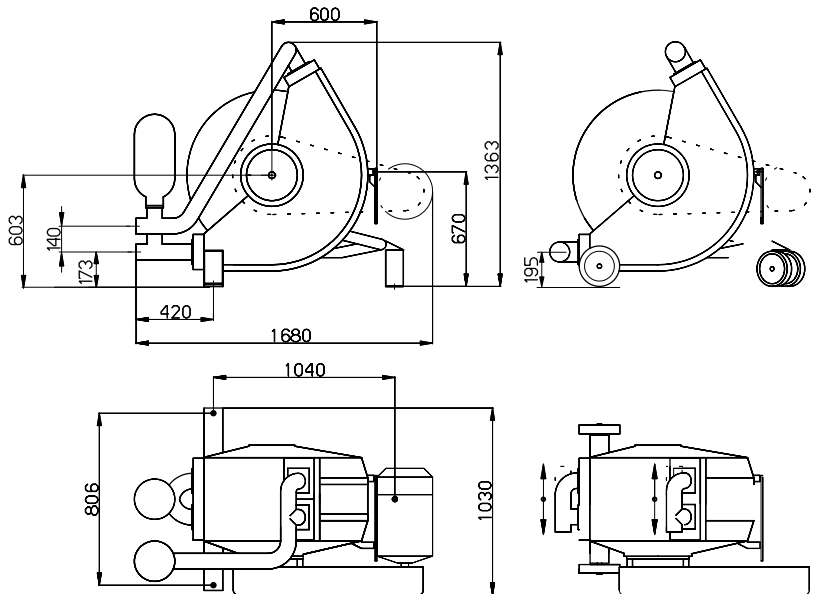

TECHNICAL DATA			
MOD.	Ø mm	LT/RPM	MAX BAR
DF	90	29	8

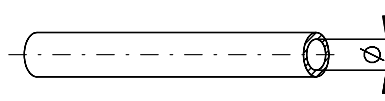

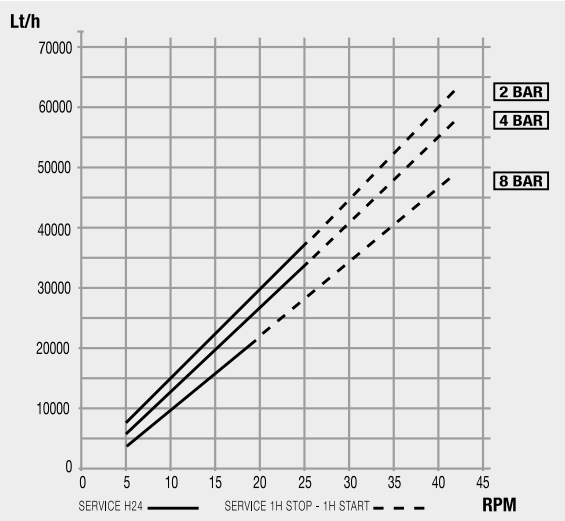

0-4 bar				
RPM	Lt/h	BAR		Kw
		std	max	
16,9	26598	2	4	11
18,8	29624	2	4	11
21,4	33766	2	4	11
23,9	37749	2	4	11
26,8	42368	2	4	11
30,1	47625	2	3	11
33,6	53201	2	2,5	11
37,6	59573	2	2,5	15
41,8	66263	2	2,5	15

4-6 bar				
RPM	Lt/h	BAR		Kw
		std	max	
16,9	26050	4	6	11
18,8	29015	4	6	11
21,4	33073	4	6	15
23,9	36974	4	6	15
26,8	41500	4	6	18,5
30,1	46650	4	6	18,5
33,6	52112	4	5	18,5
37,6	58355	4	5	22
41,8	64909	4	4	22

6 bar				
RPM	Lt/h	BAR		Kw
		std	max	
16,9	24166	6	6	11
18,8	27028	6	6	11
21,4	30945	6	6	15
23,9	34712	6	6	15
26,8	39081	6	6	18,5
30,1	44053	6	6	18,5
33,6	49326	6	5	18,5
37,6	55352	6	5	22

SR1 - SR2

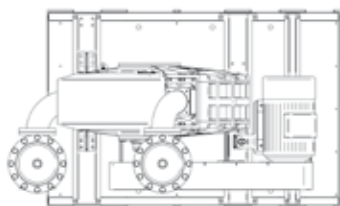
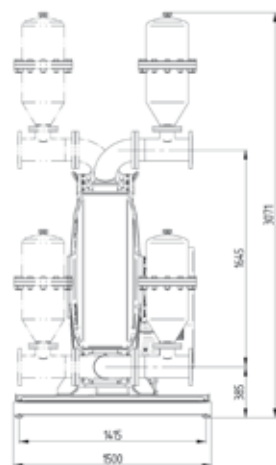
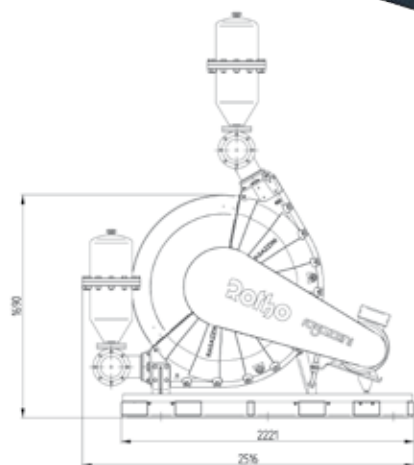

SR1

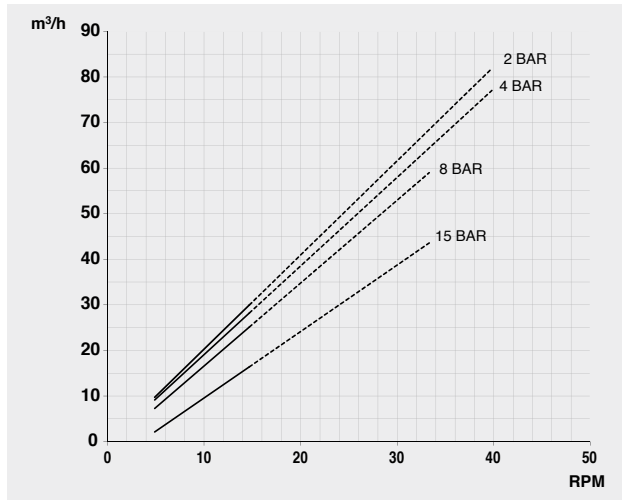

SR2

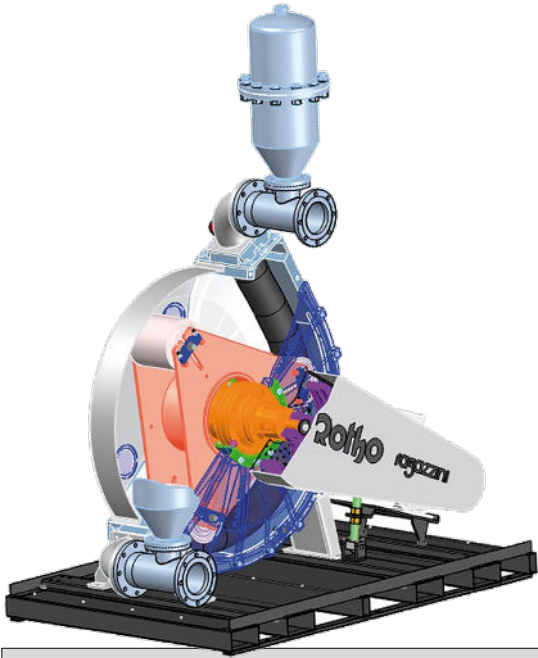
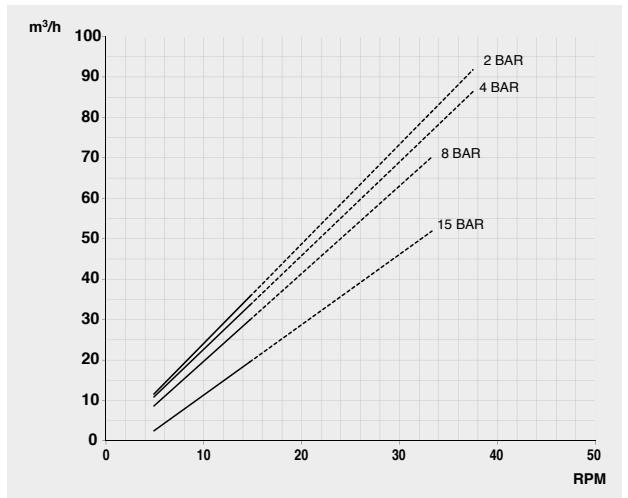

	SR1	SR2
HOSE DIAMETER	DN114	DN127
MAX CAPACITY m³/h	80	90
MAX RPM	40	37,5
MAX PRESSURE BAR	15	15
MAX POWER Kw	30	55
ANSI FL. CONNECTION	4"	5"

DR1 - DR2

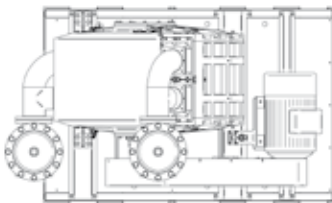
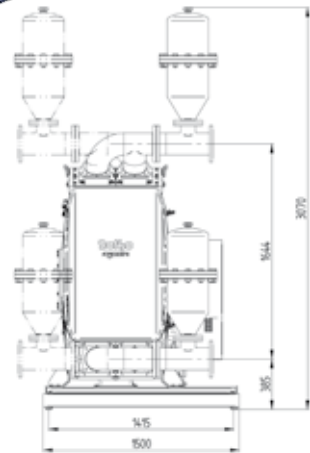
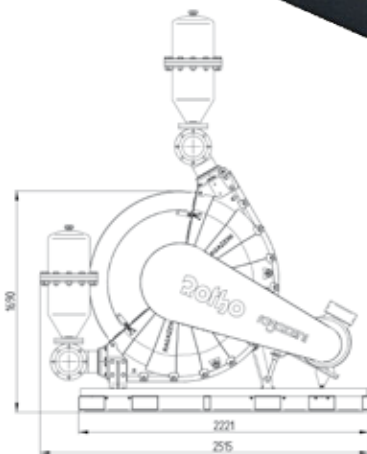

DR1

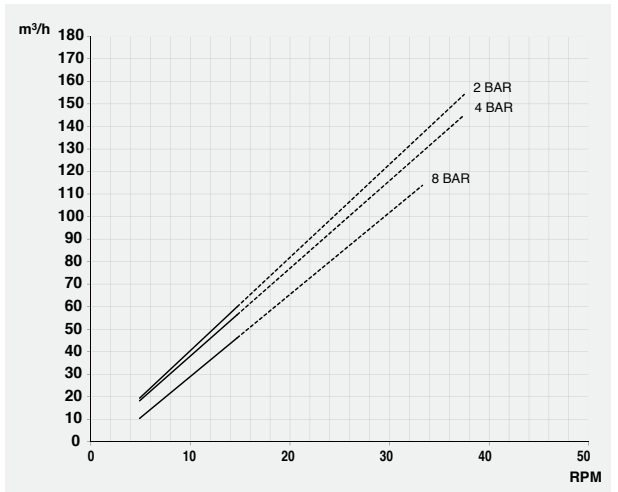

DR2

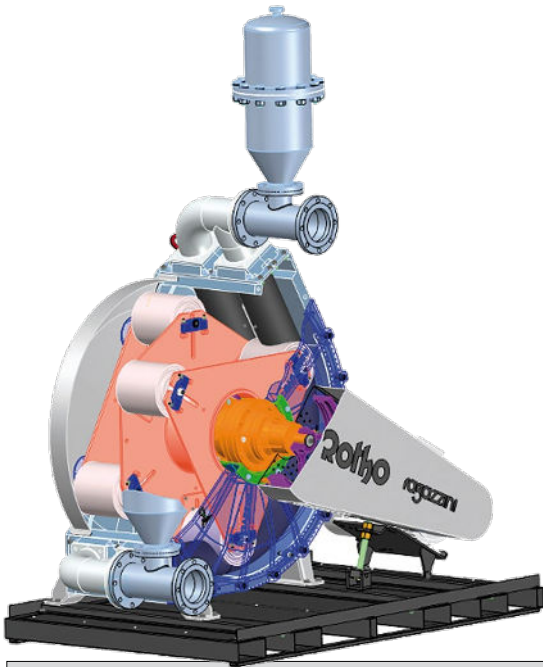
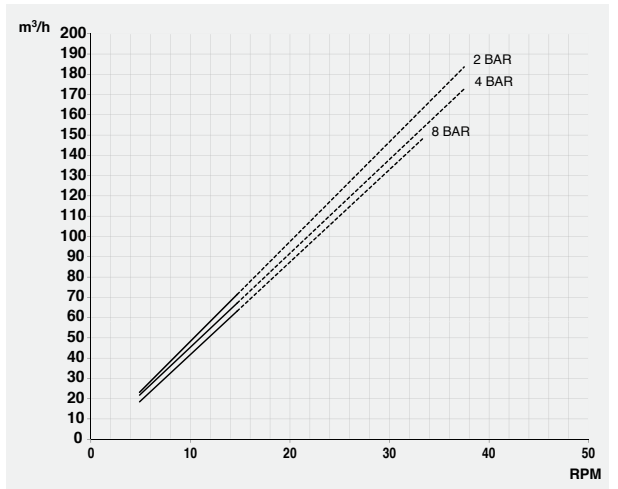

	DR1	DR2
HOSE DIAMETER	DN114	DN127
MAX CAPACITY m³/h	152	180
MAX RPM	37,5	37,5
MAX PRESSURE BAR	8	8
MAX POWER Kw	45	55
ANSI FL. CONNECTION	6"	6"

Data illustrated are not binding. The manufacturer reserves the right to make modifications without any obligation of forewarning.

ragazzini

Rotho®

ragazzini

48018 Faenza - Italy - Via A. Volta 8
Tel. +39 0546 620433 - Fax +39 0546 621394
rotho@ragazzini.it

www.ragazzini.it