



Your Partner in Safety

# Emergency Chlorine & SO2 Ton Container & Cylinder Valve Shutoff Systems

## DUPLEX II CONTROLLER

Bulletin: 903

### Features

- Controls 1 or 2 Eclipse actuators
- LED display and membrane keypad
- Menu-driven user interface
- Up to 3 days battery backup
- Shuts valve in 1 to 2 seconds
- Measures and confirms required valve torque
- Diagnostic systems with up to 23 alarms & warnings
- Meets ALL Chlorine Institute USA standards
- Individual test key for each valve actuator
- NEMA 4X, UL Listed enclosure
- Over-torque protection
- 3-year warranty



When used with our Eclipse actuators, the Duplex II allows operators to remotely close 1 or 2 chlorine or sulfur dioxide valves in an emergency situation. The Duplex II controller can interface with gas detectors, seismic or fire detectors, SCADA systems and with any number of remote mounted emergency shutoff/close switches. This allows operators to quickly and efficiently terminate a dangerous leak without having to “suit up” and enter the toxic environment.

The Duplex II controller and attached actuators are powered by an internal 12 volt, 8.5 amp hour battery. A healthy consistent battery state is maintained by an AC powered charging circuit. Should the site lose electrical power, the battery will provide system backup power for up to 72 hours. The control panel comes with an easy to read alphanumeric display, as well as a test key for each actuator so that test closures can be performed on every new tank or cylinder that is put into service. Closure of the valves happens simultaneously with both valves closing in just over 1 second.

The Duplex II controller uses our unique and patented “Torque-Sense” technology to measure the amount of torque that is applied to the valve stem. By measuring and confirming the torque applied, the Duplex II can assure operators that their valves are properly closed in any emergency situation. Optional relay packages and SCADA outputs can remotely communicate up to 23 different system diagnostics to a PLC or data acquisition system.



[www.halogenvalve.com](http://www.halogenvalve.com)



Your Partner in Safety

# Emergency Chlorine & SO2 Ton Container & Cylinder Valve Shutoff Systems

## DUPLEX II CONTROLLER

Bulletin: 903

### Specifications

- Channels:** 2 (for use with 1 or 2 actuators)
- Enclosure Weight:** 14.5 lb (6.5 kg)
- Battery Weight:** 7 lb (3.2 kg)
- Enclosure Rating:** NEMA 4X / IP67
- Temperature Range:** -10 C to 40 C
- Display:** 2 line 40 character backlit LED
- Power Requirement:** 110 - 240 VAC
- Power Use:** 100 watts
- Charging Current:** 0.9A @ 120VAC
- Charger:** Constant voltage trickle charge
- Warranty:** 3 Years
- Battery Type:** 12 Volt, 8.5 amp hour, VRLA
- Battery Backup Power:** Up to 72 hours
- Remote Mount Emergency Shutoff Switch:** Normally open contact (N.C optional)
- Optional SCADA Output:** RS-232 output of 23 system diagnostics
- Relay Outputs:**
  - **Standard Relays:** (2) Momentary N.O., 200 mA @ 24V, Conditions: Actuator A closed and torqued, Actuator B closed and torqued.
  - **Optional Relays:** (3) Dry contact, momentary or latching, NO/NC, 5A@250V. Conditions: Selectable from list of 10. See Relay Interface Module info for details.

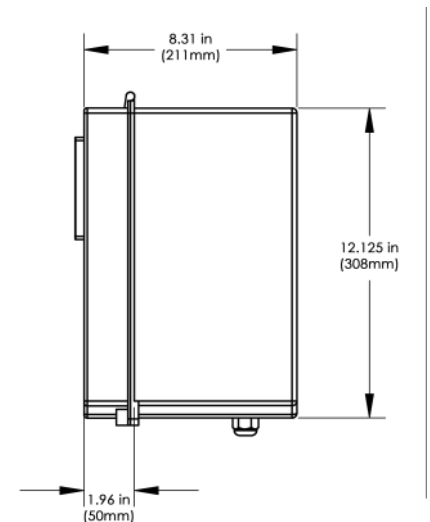
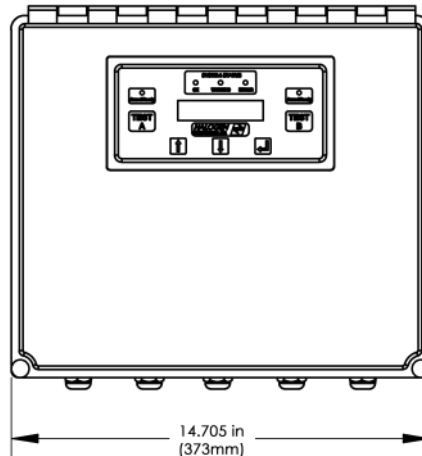

### Model Information

Image	Model	Description
	6503.14	Duplex II Controller with:
	6504.14	(1) Eclipse Actuator (2) Eclipse Actuators
		All systems come standard with Storage Bracket(s), Emergency Shutoff Pushbutton Switch, and Chlorine Valve Wrench

### Options/Accessories

Part No.	Description
4502.01	Optional SCADA output, RS-232 output of 23 system diagnostics
4500.14-S	Optional Relay Interface Module, (3) Form C dry contacts, 250 V / 5 A, 9 alarm conditions

**NOTE:** Duplex II controller requires the Eclipse actuator for a complete emergency valve shutoff system. Controllers cannot operate stand alone.

Rev 05/20